

THIEL

Passive
Subwoofer Crossover

Owner Information

Thank you for purchasing the THIEL passive subwoofer crossover. You are welcome to contact our Customer Service department with any questions or for help in setting up your system. Our contact information is: Tel: 859-254-9427 Fax: 859-254-0075 E-mail: service@thielaudio.com

THIEL Passive Subwoofer Crossovers

The THIEL passive subwoofer crossovers allow your THIEL subwoofer to reproduce both the subwoofer signal and the low frequency parts of the left/right channel signal that your main speakers cannot reproduce.

These dedicated passive crossovers match a THIEL subwoofer to a particular model of THIEL speaker. The model that your crossover is designed to be used with is marked on the unit's front panel. They allow the subwoofer to *augment* the main speakers in the precise way that will enable the combination of main speaker and subwoofer to produce perfectly balanced and blended sound, with high output bass capability to below 20 Hz. Two passive crossovers can be used with two subwoofers to provide stereo bass reproduction.

These crossovers do not redirect bass energy away from the main speakers and so the main speakers will not play any louder than they otherwise would while receiving a full spectrum signal.

Use of these crossovers provide very good performance for music and video systems when the main speakers play sufficiently loud but do not have extended, deep bass response. With these units the subwoofer will reproduce the part of the bass signal supplied to the left/right main speakers that the speakers cannot reproduce. The combination will reproduce the entire sonic range, to below 20 Hz, and provide performance equivalent to speakers with the best, most complete bass capabilities.

Hookup

The Crossover receives its input from the output of the power amplifier driving the main left/right speakers. While leaving the existing speaker cables in place, connect additional speaker wires from the power amplifier output terminals to the respective speaker level input terminals on the passive crossover unit. Be careful to connect the positive amplifier outputs to the positive crossover inputs. The cables used for these connections can be small since no power is being transferred.

For normal single subwoofer systems (reproducing the bass for both channels), the included input jumper must be removed, or damage to the power amplifier can result.

The crossover's output is supplied to the subwoofer by connecting a balanced XLR type interconnect cable from the crossover unit's output to the subwoofer's Normal Input. If you don't want the main speakers to receive the LFE signal, then an additional RCA interconnect cable is connected from the processor's subwoofer output jack to the subwoofer's LFE Input (see following section).

If two subwoofers are used for stereo subwoofer operation, the subwoofer for each channel needs to connect to its own passive crossover which is driven by only the left or right channel signal. Each crossover must have the included input terminal shorting jumper in place for the unused channel's input.

Setting the Surround Processor

The surround processor should be set to deliver the left/right channel bass to the main speaker channels by telling it that the main speakers are full-range, or "large", even if they are not.

In a video system with a subwoofer output, there are two methods of supplying the subwoofer channel signal to the subwoofer.

Method 1 is to tell the processor that you do *not* have a subwoofer (even though you do) so that it will mix the subwoofer signal into the main speaker channels where it will be directed to the subwoofer by the crossover. The advantage of this method is that it automatically provides the correct level balance of the subwoofer channel signal. The disadvantage of this method is that the main speakers will receive the subwoofer signal and therefore may not be able to play as loudly as otherwise. If you try this method and you do experience speaker overloading when reproducing demanding bass you should use method 2. With method 1 you do not use the processor's subwoofer output and the subwoofer's LFE level control should be set to minimum.

Method 2 is to tell the processor that you do have a subwoofer. It will then supply the subwoofer signal to the subwoofer output. You must then connect this output directly to the subwoofer's LFE input using an RCA type unbalanced interconnect cable. The advantage of this method is that the main speakers will not receive the demanding subwoofer signal and will play as loudly as their abilities and the amplifier power will allow. When this method is used, the subwoofer signal's level must be adjusted to balance the main speaker's loudness.

It is usually more convenient to adjust the subwoofer level with the processor's subwoofer level control, and in this case a good starting point for the subwoofer's LFE level control is 110. If the system's processor cannot control subwoofer level, then the subwoofer's level control is used. The level can be adjusted "by ear" to achieve a pleasing balance so that the low frequency effects are not too weak or too strong or, preferably, a sound level meter can be used in combination with a noise generator in the processor, if available. Adjust the subwoofer level so that you get the same sound level reading from the subwoofer channel as from the left and right channels.

System connections

This shorting strap must be removed if both left and right channel inputs are used. This shorting strap must be installed across unused channel terminals if only left or right channel input is used for stereo subwoofer systems.

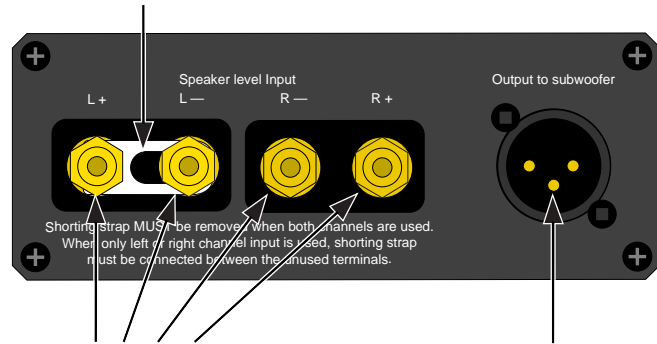

The shown connection from the processor to the sub is optional; if used, it keeps the LFE signal from the main speakers but requires a separate LFE level adjustment. If this connection is *not* used, tell the processor that you do not have a subwoofer (even though you do) and set the subwoofer's LFE level control to minimum. And in any case, tell the processor that the main speakers are large, even if they are not.

Input wires are connected from the main speakers' power amplifier outputs to these input terminals. Observe + and - polarity markings.

A balanced XLR type interconnect cable is connected from this output to the subwoofer's normal input.

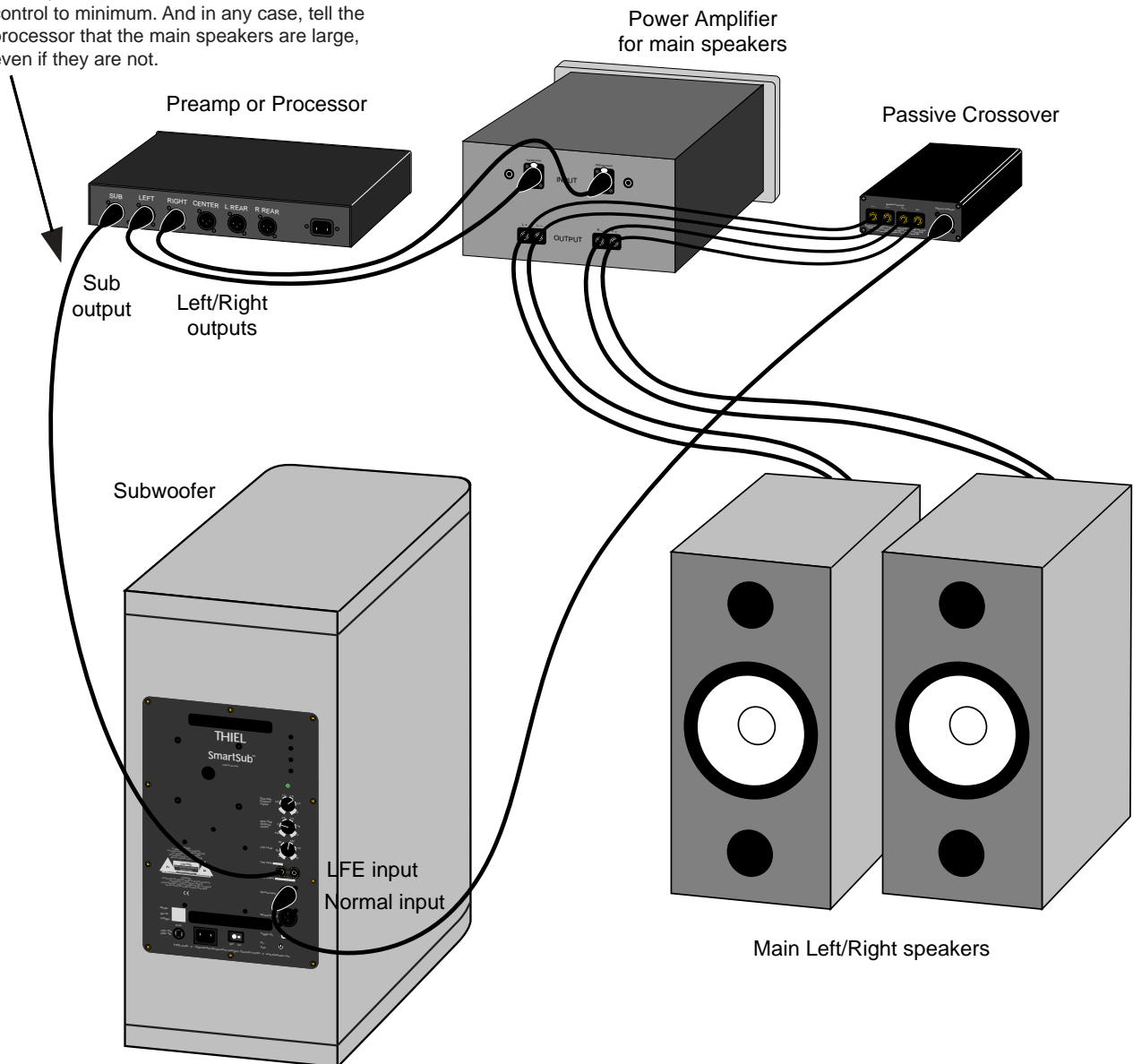

THIEL

1026 Nandino Blvd., Lexington, KY 40511

Tel: 859-254-9427 • Fax: 859-254-0075 • Email: mail@thielaudio.com • www.thielaudio.com